

Care 300

4.5/3 litre Dual Flush Toilet Suite for People with Accessible Applications



A pedestal type 4.5/3 litre dual flush **Care Pan** installation designed to provide a raised seat height of between 460-480mm for people with accessible applications . The versatility of the **Care Pan** makes it ideal for use by both the ambulant people with disabilities and wheel-chair users including wheeled commode chairs.

Important: Further reference must be made to **A.S.1428.1-2009 with current amendments to determine circulation space, grab rail and installation requirements. The dimensions in this sheet may change with amendments to the standard.**

- Pan:** Concorde Care connector pan 4.5 litre full flush washdown type.
- Traps:** S-trap and P-trap (WELS 4 star rated) unvented only. Slope of P-trap 95°
- Inlet:** 50mm back inlet.
- Cisterns:** Sovereign 4 Star Cistern (wall fix version). **Important: Working pressure minimum 30kPa to maximum 1000kPa flow pressure. Rain water tank compliant.**
- Buttons:** Round Care Button - Metal (supplied). Other button options sold separately. See section 4.01 for further details
- Seats:** Caravelle Care seat supplied, available in Caroma White (W), Sorrento Blue (SB) and Anthracite Grey (AG). See Section 3 SEATS for further details.
- Position of the Pan:** For wheel chair access the installed pan must be a minimum of 800 ± 10mm from the front of the pan to the finished wall and provide a seat height of 460 to 480mm. The projection requirements for people with ambulant disabilities is 610 to 660mm.
- Position of the Cistern:** The underside of the cistern must be 600mm minimum from the finished floor. The push button height must be no greater than 1100mm from the finished floor.
- Colours:** White only.
- Installation:** The installation of the toilet suite shall be in accordance with the normal minimum drainline grade requirements in AS/NZS 3500.2.
- Dimensions:** All dimensions are in millimetres and are subject to normal manufacturing variations. Caroma pursues a policy of continuing improvement in design and performance of its products. The right is therefore reserved to vary specifications without notice.



Note: The projection requirements detail on this illustration are for wheel chair access only. The projection requirements for people with ambulant disabilities is 610 to 660mm.

All height dimensions to underside of pan, make allowance for mortar bedding.

Mortar bedding: The pan should be fixed to the floor with a sand cement mixture of 3:1 to a depth of 60mm. When bedded the back of the foot of the pan should be approximately 10mm above the finished floor.

Screw fixing: The pan should be bedded with an acetic cured silicone sealant and fixed with corrosion resistant screws and pan guard washers. Use Caroma pan fixing kit. Code No.601150.

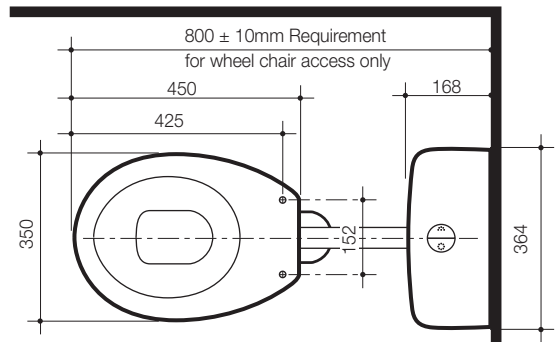
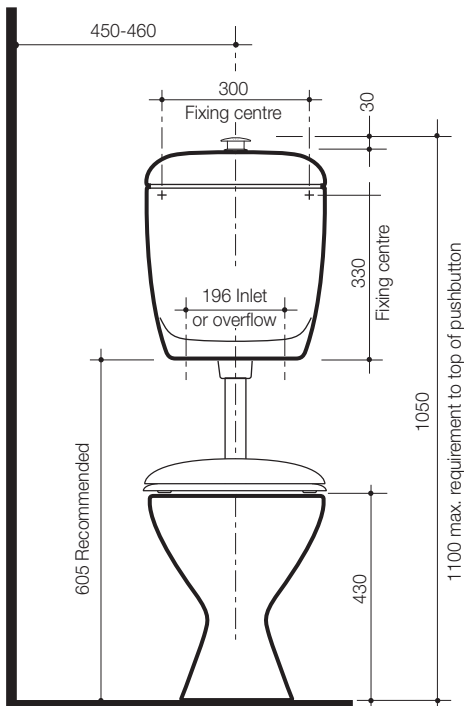

Care 300 Toilet Suites:
With Caravelle Care Seat —

		Code No.	Seat colour:
Single Flap	S trap	987904	W, SB or AG
	P trap	987902	W, SB or AG
Double Flap	S trap	987905	W, SB or AG
	P trap	987903	W, SB or AG

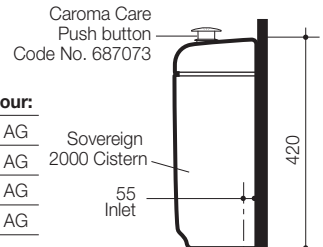

Note: The lid on a double flap toilet seat is not suitable to be used as a support for users.

