

OVERMOUNT TEMPLATE CUTOUT USE OUTSIDE LINE

UNDERMOUNT TEMPLATE CUTOUT USE INSIDE LINE

Overmount
Cutout Line

Undermount
Cutout Line



Luna Round Sink

INSTALLATION INSTRUCTION FOR OVERMOUNT SINK

- 1a. Inspect sink for damage and dimensional compatibility. Do not attempt to install a damaged sink.
- 2a. Using the cutout template mark the exact location of the required cutout in the benchtop and draw a pencil line against the edge of the template.
- 3a. Ensure that the tap location is suitable. Ensure that the supplied cutout gives the desired fit.
- 4a. Before commencing cutting, double check the marked cutout dimensions. Cut out the bench top carefully following the inside edge of the marked line. An exact cut is required to obtain the best fit.
- 5a. For normal thickness bench tops, the attached fixing clips should be suitable. Lightly hammer the fixing clips onto the clip brackets at equal points along the product rim. (If the thickness of the bench top exceeds the range of the fixing clips then extension clips can be purchased and mounted onto the clip brackets. See Figure B)
- 6a. Position the sink in the cut out hole and align properly. The fixing clips can be bent out of the way to assist installation (see Figure C). Check that the sink sealing tape will seal evenly around the edge of the hole.
- 7a. Remove the sink and if required install the waste assemblies and the tap. It is suggested that silicone sealant be applied between the waste grate and the sink outlet hole.
- 8a. Remove the protective backing from the sealing tape, apply a continuous bead of silicone sealant between the sealing tape and the edge of the sink and quickly place into position.
- 9a. Bend the fixing clips straight so that the legs clear the hinge area. Tighten the clips evenly using a low torque setting (see Figure D). Note: over tightening the clip may strip the thread.
- 10a. Plumb up the tap and waste fittings.

NOTE: For thin bench tops special clips (A0167) are available.

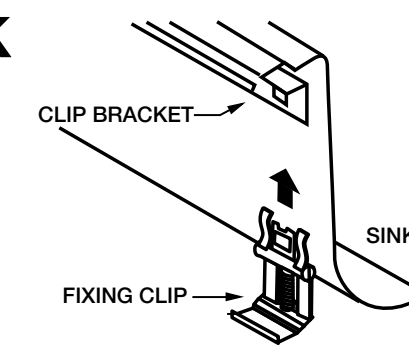

FIGURE A

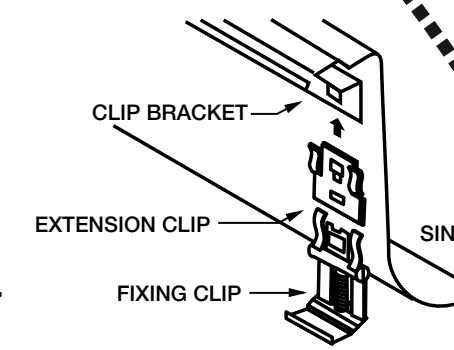

FIGURE B

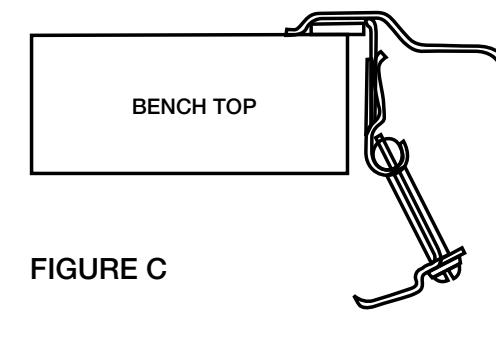

FIGURE C

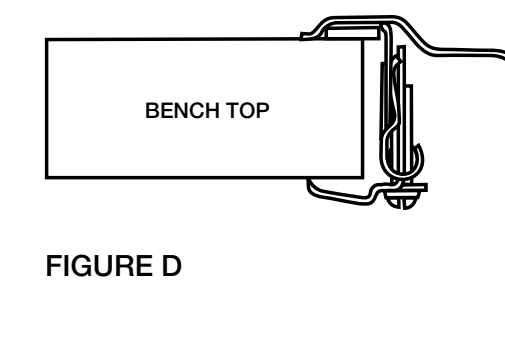

FIGURE D

INSTALLATION INSTRUCTION FOR UNDERMOUNT SINK

- 1b. Inspect sink for damage and dimensional compatibility. Do not attempt to install a damaged sink.
- 2b. Undermount sinks are designed for use with solid surface benchtops, examples as follows;
 - Natural Stone eg. Marble, Quartz etc
 - Engineered stone eg. CaesarStone, Silestone etc
 - Acrylic solid surfaces eg. Corian, Freestyle, Staron etcIt is not recommended that undermount sinks be fitted to laminate benchtops. Contact your benchtop supplier to establish the type of material used. Your supplier should recommend a suitable adhesive and sealant for the specified material.
- 3b. Using the cutout template mark the exact location of the required cutout in the benchtop. Ensure that the tap location is suitable. Ensure that the supplied cutout gives the desired fit.
- 4b. Before commencing cutting, double check the marked cutout dimensions. Using the appropriate tools and safety equipment cut the benchtop as marked out.
- 5b. Mask the sink and the cutout to avoid sealant/epoxy overspill onto finished surfaces.
- 6b. Apply the recommended sealant at the edge of the join between sink and benchtop.
- 7b. Apply the recommended adhesive as directed by adhesive supplier.
- 8b. Position the sink in the desired final location and clamp to the benchtop.
- 9b. Promptly remove excess sealant from benchtop and sink using a recommended clean up solvent suitable for your benchtop material and stainless steel.
- 10b. When the installation has cured for the recommended period check that the seal is watertight and the attachment is secure.

Caroma bears no responsibility for faulty installation and the effects thereof.

CUTOUT TEMPLATE DIMENSIONS
Overmount: 434mm diameter
Undermount: 406mm diameter

This carton contains the following components

Overmount Installation Fixing Clips

90mm Basket Waste Outlet

Please check that all components are included

before commencing installation.